

DXM/64x64 and DXM/128x128 SERIES SOLID STATE HIGH SPEED DIFFERENTIAL DATA SWITCHING MATRICES for ECL, PECL, CML & More

CYTEC's DXM Series switching systems are solid state, full fan-out matrices available in 16x16 through 128x128 configurations. At the switch fabric level, CML Inputs are switched to CML Outputs. Input and Output Buffers are added to allow ECL, PECL, LVPECL, LVDS or fast RS422 two wire differential signal switching. CML supports data rates to 3.2 Gbps. Other data rates are as high as 2 Gbps (NRZ). Control is via the new IF-8 RS232/GPIB/Ethernet Control Module.

TYPICAL APPLICATIONS INCLUDE:

- Programmable routing of fast differential signals for telemetry applications.
- Signal distribution for communications and test.
- Automated patch panels.

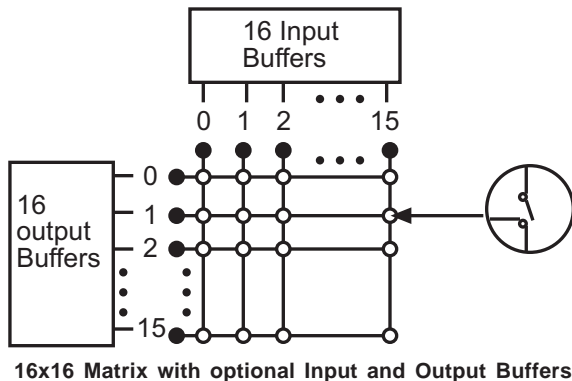

SYSTEM HIGHLIGHTS:

- Matrices are non-blocking and full fan out.
- 64x64 and 128x128 chassis sizes are offered.
- Modular design - Systems can be configured in increments from 16x16 to 128x128 matrix sizes.
- Different buffer modules provide for signal transformations; i.e., ECL Inputs and LVDS Outputs.
- Clock/Data configurations available.
- Buffer and control modules are hot-swappable.
- Control via IEEE488, RS232 & Ethernet all standard.
- Firmware upgrades can be downloaded from Cytec's web site.
- Chassis' Densi-Shield I/O connectors can be wired out to patch panels with SMAs, BNC, etc.
- Switch fabric cleans up signal jitter and rise times.

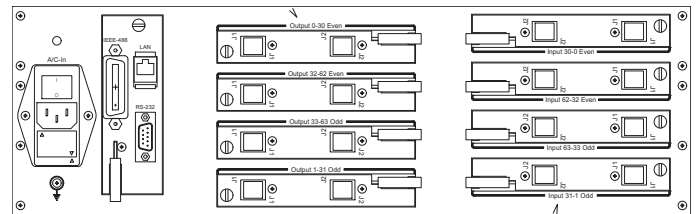

DXM/64x64 Mainframe Chassis

DXM CHASSIS

The DXM Chassis are standard 19" rack mounting anodized aluminum chassis that are built with RS232, IEEE488 and Ethernet controls. Any input connects to any or even all outputs. Systems switching Clock & Data pairs are also available. Densi-Shield input and output connectors are standard, while other connectors such as SMA or BNC can be wired out on patch panels.

The following chassis are offered:

DXM/64x64 Mainframe- 5.25" high (3U) and 15.6" deep. Configurations range from 16x16 to 64x64 matrices.

DXM/32x32 Clock/Data Mainframe - also a 5.25" high and 15.6" deep chassis. Switches Clock & Data signals together in parallel. Available as 16x16 or 32x32 matrices.

DXM/128x128 Mainframe- 14" high (8U) and 15.6" deep. Configurations from 16x16 to 128x128 are offered.

DXM/64x64 Clock/Data Mainframe- Switches Clock & Data signals together as pairs. 8U by 15.6" deep. Available in configurations ranging from 16x16 to 64x64 matrices.

DXM-E Expansion Chassis - are used to build larger systems. Multiple DXM Chassis can be controlled from one MESA II Control Chassis shown as in the **MESA Bulletin**.

Custom configurations are available on request.

**FOR TECHNICAL ASSISTANCE, PLEASE CONTACT CYTEC AT
800-346-3117 OR VISIT OUR WEBSITE AT cytec-ate.com**

SPECIFICATIONS AND BUFFER OPTIONS

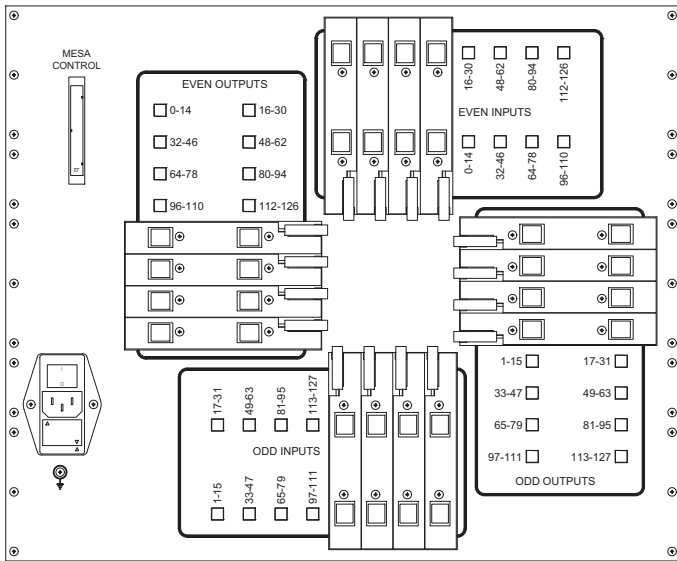

DXM/128x128 Expansion Chassis with Densi-Shield Signal Connections

DXM SERIES MATRIX

The DXM Series switches high speed differential signals such as ECL, PECL, CML, LVDS, RS422 in a nonblocking (any input to any output) and full fan out (any input to any or all outputs) configuration. A solid state switch fabric is at the heart of the system. The basic chassis holds the control module, power supplies and switch fabric. The system is completed by adding the required input and output buffers. The buffers provide signal level transformations for the different signal types.

INPUT and OUTPUT BUFFER MODULES

The DXM Series switching systems are built with input and output buffer modules. Buffer modules are required to convert external signals (such as ECL, PECL, LVDS, etc.) to CML levels that can be handled by the solid state fabric at the heart of the switch. The switch fabric outputs CML levels which are then converted by the output buffers back to the original signal, or to a different signal type (i.e., ECL in to LVDS out) if required by the end user.

Each buffer module handles 16 differential signals. Thus, for a 16x16 configuration, one input and one output buffer module are required. Similarly, four input and four output buffer modules are needed for a 64x64 matrix, while eight of each are needed for a 128x128.

FCI DENSI-SHIELD I/O CONNECTORS

Each buffer is built with two Densi-shield connectors, and each connector handles eight differential pair signals as shown below. These connectors can be wired out to optional patch panels that provide BNC, SMA, Triax, etc., connectors.

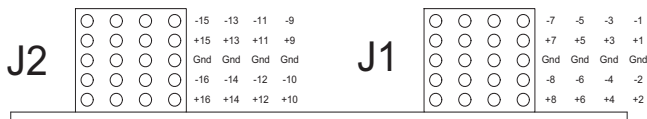

Buffer Module Densi-Shield Connectors

INPUT/OUTPUT BUFFER SPECIFICATIONS

CML INPUT/OUTPUT BUFFER MODULES

The CML Input Module AC couples all inputs and provides pull up circuits to prevent unused inputs from floating and picking up crosstalk from live adjacent signals. CML Output Modules accept CML signals from the switch matrix crosspoint IC and pass them on to the output Densi-Shield connectors.

SPECIFICATIONS

Max. Data Rate (NRZ)	3.2 Gbps
Vdiff - Input Diff. Vpp	0.2 V min., 2.0 V max.
Vodiff - Output Diff. Vpp	0.5 V min., 0.8 V max.
Channel Propagation Delay	3.8 nsec. typ., 4.25 nsec max.
Ch-Ch Propagation Skew	75 psec typ., 125 psec max.

FAST RS422 OUTPUT BUFFER MODULES

These modules are intended to work with typical RS422 signal levels of 0 to 5 volts. Differential signals terminate into 100 ohms across differential pairs. Vcc is typically 3.5 V for the inputs and 5 V for the output modules.

SPECIFICATIONS

Max. Data Rate (NRZ)	60 Kbps min., 40 Mbps max.
Voh - Output V High	3.4 V min.
Vol - Output V Low	0.4 V max.
Channel Propagation Delay	3.8 nsec. typ., 4.25 nsec max.
Ch-Ch Propagation Skew	75 psec typ., 125 psec max.

LVDS OUTPUT BUFFER MODULES

Work with typical LVDS signal levels of 1 to 1.4 volts. Differential signals terminate into 100 ohms across differential pairs. Vcc is approximately 3.0 V.

SPECIFICATIONS

Max. Data Rate (NRZ)	60 Kbps min., 1.6 Gbps max.
Voh - Output V High	1.474 V max.
Vol - Output V Low	.925 V min.
Vocm - Output Com Mode V	1.125 V min., 1.375 V max.
Vodiff - Output Diff. V	250 mV min., 450 mV max.
Channel Propagation Delay	3.8 nsec. typ., 4.25 nsec max.
Ch-Ch Propagation Skew	75 psec typ., 125 psec max.

ECL OUTPUT BUFFER MODULES

ECL modules are intended to work with typical ECL signal levels of -1.8 to -0.8 volts. Differential signals terminate into 50 ohms tied to -2 V. Vee is usually -5 V, while Vcc is GND.

SPECIFICATIONS

Max. Data Rate (NRZ)	60 Kbps min., 3.0 Gbps max.
Voh - Output V High	-0.810 V max.
Vol - Output V Low	-1.950 V min.
Io Output Current Continuous	50 mA
Channel Propagation Delay	3.8 nsec. typ., 4.25 nsec max.
Ch-Ch Propagation Skew	75 psec typ., 125 psec max.

FOR TECHNICAL ASSISTANCE, PLEASE CONTACT CYTEC AT 800-346-3117 OR VISIT OUR WEBSITE AT cytec-ate.com

CONTROL & POWER SUPPLY REDUNDANCY/HOT SWAPPABILITY

MESA II CHASSIS w/ Redundant Controls

The MESA II is a 19" rack mounting chassis, 5.25" high and 15" deep. It accepts one or two of the CM-8 IEEE488/RS232/Ethernet Control Modules and also has expansion ports that control up to 16 expansion chassis. All three remote interfaces can be in use at the same time. The MESA II is optimized to control several large solid state expansion chassis, such as the DXM and DX/256x256 Series.

Redundant, Hot Swappable Controls

The MESA II can hold two of the hot swappable CM-8 IEEE488/RS232/Ethernet LAN Control Modules. Two control modules provide for redundancy, increasing system availability.

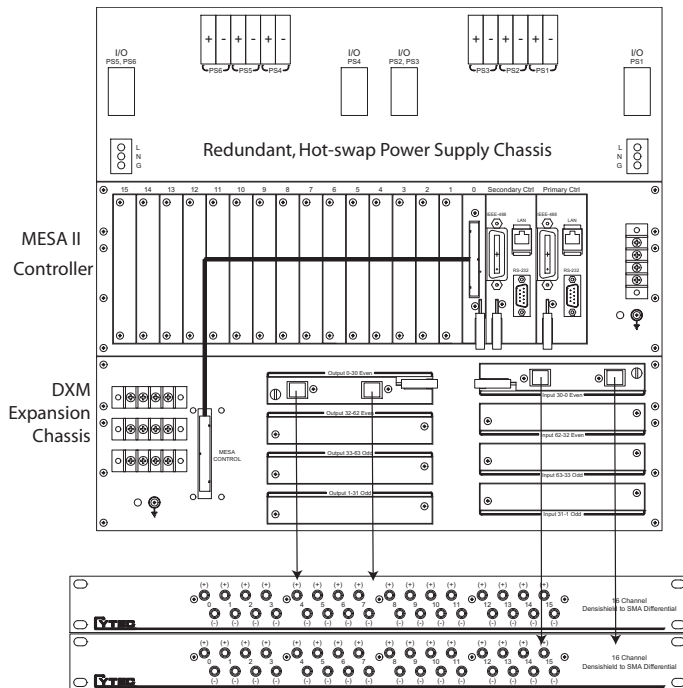

DXM 16x16 system consisting of one DXM expansion chassis, one MESA II with redundant controls and two redundant power supply chassis. SMA connectors are wired out on a separate Patch Panel.

REDUNDANT/HOT SWAPPABLE POWER SUPPLY CHASSIS

The DXM Series chassis are powered by either standard internal power supplies or optionally via externally located rack mounting power supply chassis. Each rack mounting power chassis holds several plug in, hot swappable power modules, with at least two redundant modules supplying each required voltage. Typically, two separate power supply chassis are required to furnish all voltages. The separate rack mounted power supply chassis increases system availability by furnishing supplies that are both redundant and hot swappable. (See adjacent image)

DXM EXPANSION CHASSIS

DXM chassis can be built as expansion chassis and used with Cytec's new MESA II Control Chassis. Expansion chassis allow large or complex systems to be set up using a single point of control. Using a Mesa II Controller and one or more expansion chassis has the following advantages:

Cost Savings

Expansion chassis do not require their own control modules or manual controls, adding up to cost savings that pay for the MESA on any system requiring three or more expansion chassis.

Single Point of Control

You can control up to 16 DXM chassis, or combinations of different chassis types, from a single MESA II. The MESA allows control of several chassis from one GPIB address, RS232 Port or LAN IP address.

Remotely Located Switch Chassis

Expansion chassis can be located up to 125 feet away from the MESA. Thus switching chassis can be located where needed and still not require separate controls.

Complex Test Systems

Since any Cytec chassis can be controlled via the MESA, you can build complicated systems switching a number of different signal types by using different Cytec products for each signal type.

CONNECTORIZED PATCH PANEL OPTIONS

The DXM series chassis have I/O buffer modules that are built with high density Densi-Shield connectors. These native connectors can be wired out to other common types including SMAs, BNCs, Triax, etc., located on separate rack mounting patch panels. (See adjacent image for a 16x16 matrix system using patch panel mounted SMAs)

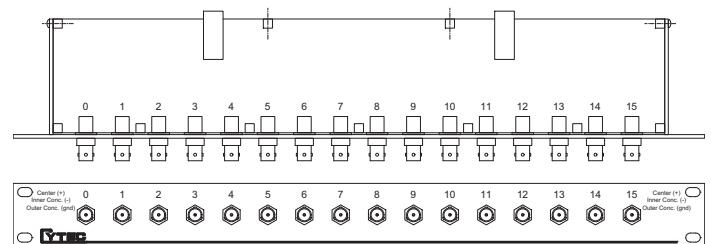

48-23-10 16 channel Triax Patch Panel

Patch Panels allow you to connect and disconnect the switch quickly without disturbing the SMA, BNC or Triax Connections greatly reducing MTTR and long term MTBF.

Cytec can produce patch panels with almost any connector desired. Don't see it? Just call and ask!

FOR TECHNICAL ASSISTANCE, PLEASE CONTACT CYTEC AT 800-346-3117 OR VISIT OUR WEBSITE AT cytec-ate.com

DXM GENERAL SPECIFICATIONS

Connections	Densi-Shield signal connections, AC input and remote control input. Optional signal connectors such as SMA, BNC and Triax are available on wired-out patch panels.
Control	RS232, IEEE488 and Ethernet all standard. Manual keypad optional.

ENVIRONMENTAL

Dimensions/Weight	19' rack mount, less than 45 lbs
- DXM/64x64	5.25" high x 15.6" deep
- DXM/128x128	14" high x 15.6" deep

POWER

AC Input	90-264 volts AC, 47-63 Hz, < 100 W
DC Supply Type	High efficiency switching

SIGNALS

Capacity	
- DXM/64x64	Up to 64x64 Matrix OR 32x32 Clock/Data configuration
- DXM/128x128	Up to 128x128 Matrix OR 64x64 Clock/Data configuration
- Expansion	Mesa Controller allows expansions up to 128x128 Clock and Data or higher.

Switch Fabric	Vitesse VSC3138/VCS3140 crosspoint ICs CML inputs, CML outputs. Data rate to 3.5 Gbps NRZ helps restore signal levels, corrects deterministic jitter and rise time problems associated with long cable runs.
----------------------	--

MISCELLANEOUS

Switching Speed	100 ns plus any computer delay
MTBF	50,000 hours (Telcordia)

ALL CHASSIS

Material:	Gray anodized extruded or sheet aluminum
Mounting Hardware:	Rack mount handles are standard. Flush mount flanges available at no extra cost.
AC Power:	Autoranges from 90 - 264 VAC at 47-63 Hz

WARRANTY

CYTEC Corp. warrants that all products are free from defects in material or workmanship for a period of five years.

CONTROL OPTIONS

IF-8 IEEE488, RS232 & ETHERNET LAN

Are standard for DXM Mainframes. All interfaces may be active and in use simultaneously. Setup information is stored in NVRAM, which allows the system to be configured for various matrix addressing combinations which are then remembered. The IF-8 may be removed without affecting the switch state. However, installing an IF-8 will cause the system to clear and reset.

CM-8 MESA II CONTROL MODULE

The CM-8 installs in the MESA II Control Chassis ONLY and has three remote control interfaces: RS232 via a D9 connector, IEEE488 Talk/Listen and 100BaseT Ethernet via a RJ45 45 port. All interfaces can be active at the same time. As an option, two CM-8's can be installed in the MESA II, with one Control Module designated the Primary and the second designated as the Secondary controller. The control modules are hot swappable, meaning they can be removed and then replaced without shutting down the MESA or the full switching system. Network parameters can be set up via any of the remote interfaces.

Control is via the same commands shown in the CM-5 Control Module section.

MANUAL CONTROL OPTIONS

MC-2 Keypad Manual Control

This optional front panel control includes a keypad and LCD display. The operator can open, close and verify the status of any switch point.

CUSTOMIZED SYSTEMS

Cytec can generally customize a system to meet specific requirements with little or no additional Non-Recurring Engineering (NRE) charges. Typical customizations include: special labeling, configurations, chassis dimensions and mounting options or components. Don't see what you need? Contact Cytec and one of our Sales Engineers will be happy to work with you.

SOFTWARE

Free drivers and/or sample programs are available for the most commonly available application programming languages.

CYTEC SWITCH MANAGER SOFTWARE



The Cytec Switch Manager provides a GUI interface for controlling matrices and multiplexers via remote computer. The software includes an intuitive graphical interface, security implementation, built in test functionality, multiple device control, switchpoint memory, as well as many other useful features. You can download the Switch Manager free of charge from our website.

Available for Windows, Linux, Mac OS, or any other Java enabled platform

FOR TECHNICAL ASSISTANCE, PLEASE CONTACT CYTEC AT 800-346-3117 OR VISIT OUR WEBSITE AT cytec-ate.com